

# Modello bruciatore: GB-ML 450 N MC

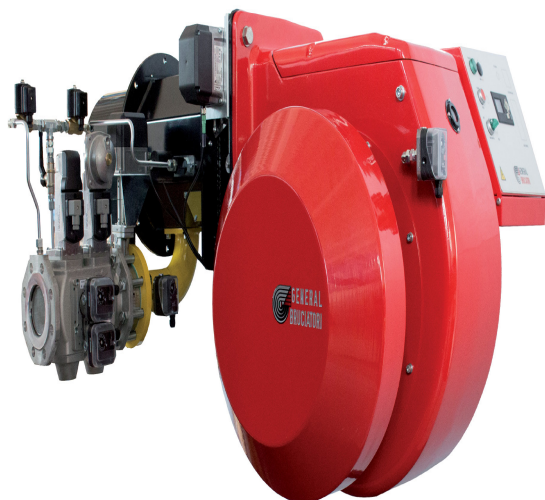

**Combustibile:** GAS - Olio Combustibile  
**Nm3/h:** -  
**kW:** 1200 - 4800  
**Motore Ventilatore kW:** 7  
**Motore pompa kW:** 2

## Scheda Tecnica

**GB-ML 450 N MC**

---

**Testa di Combustione**

---

**Applicazioni Principali**

---

**Corpo Bruciatore**

A	B	C	?D	E	F	G	L	P	Q	R	V	X *	Z	? STUD BOLT
330	396	306	14	232	123	460	529	230	600	534	1325	525	1850	M12 X 50

# Disegno Tecnico

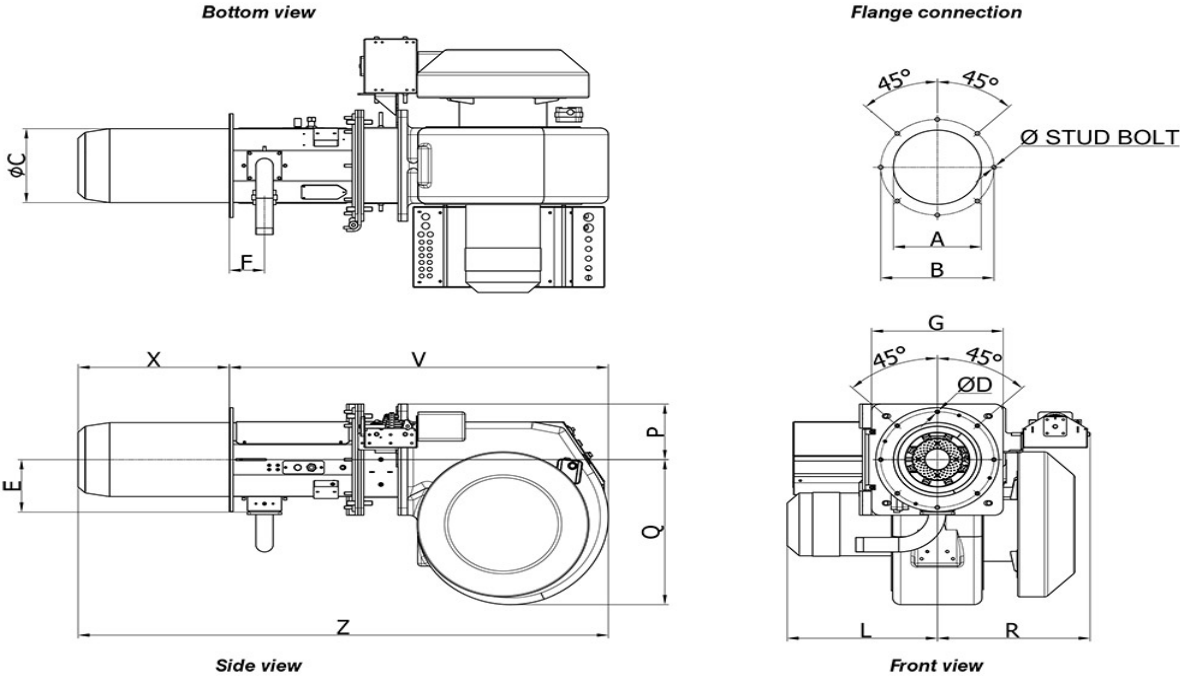

# Grafico Bruciatore

