

Modello bruciatore: GB-ML 450 GN MC

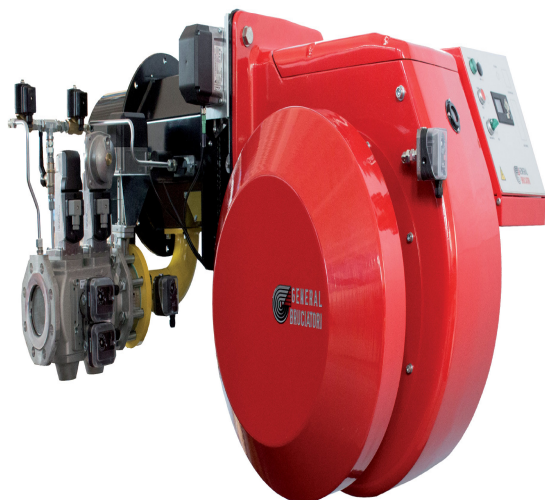

Combustibile:
Nm3/h: 80 - 485
kW: 800 - 4800
Motore Ventilatore kW: 7
Motore pompa kW: 2

Scheda Tecnica

GB-ML 450 GN MC

Testa di Combustione

Applicazioni Principali

Corpo Bruciatore

A	B	C	?D	E	F	G	L	P	Q	R	V	X *	Z	? STUD BOLT
330	396	306	14	232	123	460	529	230	600	534	1325	525	1850	M12 X 50

Disegno Tecnico

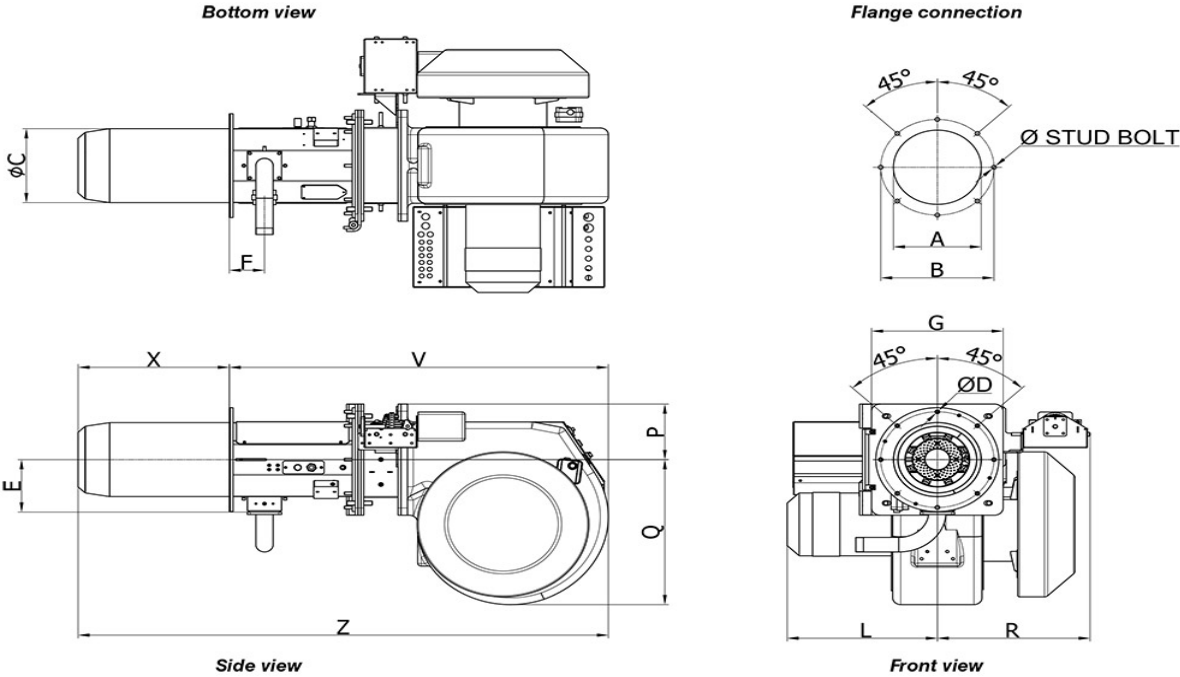

Grafico Bruciatore

